

Table Showing S2 Bar Lengths

Int. Bent No. 2		Int. Bent No. 3	
Span 1	Span 2	Span 2	Span 3
'-"	'-"	'-"	'-"

U.I.P., REDECK AND MAKE COMPOSITE EXISTING (__'-__'-__') CONTINUOUS WIDE FLANGE BEAM SPANS

Required Lap Length For Bar Splices **

Bar Size	Splice Length
4	2'-7"
5	3'-3"
6	3'-10"
7	4'-11"

** Unless otherwise shown.

General Notes:

Design Specifications:

2002 AASHTO LFD (17th Ed.) Standard Specifications
Seismic Performance Category A

Design Loading:

HS (19) (Existing)
HS20-44 (New Construction)
35 lb/sf Future Wearing Surface
Earth - 120 lb/cf, Equivalent Fluid Pressure 45 lb/cf
Fatigue Stress - Case III

Design Unit Stresses:

Class B-1 Concrete (Barrier) $f'c = 4,000$ psi
Class B-2 Concrete (End Bents & Superstructure, except Barrier) $f'c = 4,000$ psi
Reinforcing Steel (Grade 60) $fy = 60,000$ psi

Joint Filler:

All joint filler shall be in accordance with Sec 1057 for preformed sponge rubber expansion and partition joint filler, except as noted.

Reinforcing Steel:

Minimum clearance to reinforcing steel shall be 1 1/2", unless otherwise shown.

Miscellaneous:

Protective coating for concrete bents and piers (Urethane or Epoxy) shall be applied as shown on the bridge plans and in accordance with Sec 711.

Bars bonded in existing concrete not removed shall be cleanly stripped and embedded into new concrete where possible. If length is available, existing bars shall extend into new concrete at least 40 diameters for plain bars and 30 diameters for deformed bars, unless otherwise noted.

Roadway surfacing adjacent to bridge ends shall match new bridge slab surface. (Roadway item)

Outline of existing work is indicated by light dashed lines. Heavy lines indicate new work.

Contractor shall verify all dimensions in field before finalizing the shop drawings. ④

The area exposed by the removal of concrete and not covered with new concrete shall be coated with an approved qualified special mortar in accordance with Sec 704.

Rubblized concrete from the existing bridge deck that qualifies as clean fill may be placed on spill slopes at end bents above ordinary high water line (Roadway item). ②

For adjusted girder deflection due to the weight of the new deck and barriers, see Bridge Electronic Deliverables.

Traffic Handling:

Structure to be closed during construction. Traffic to be maintained on during construction. See roadway plans for traffic control and Sheet No. for staged construction details.

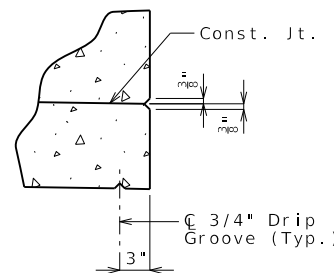

DETAIL B

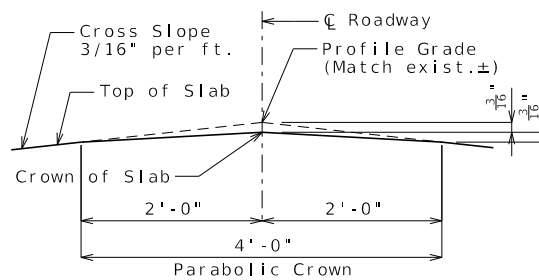

DETAIL A

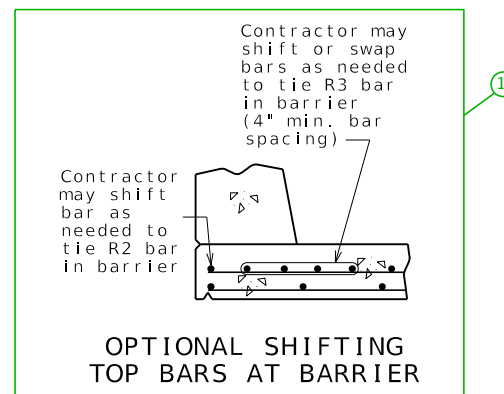

OPTIONAL SHIFTING TOP BARS AT BARRIER

Estimated Quantities		
Item		Total
Removal of Existing Bridge Deck	sq. foot	X
Partial Removal of Substructure Concrete	lump sum	1
Slab on Steel	sq. yard	X
Type D Barrier	linear foot	X
Protective Coating - Concrete Bents and Piers (Urethane)	lump sum	1
Shear Connectors	each	X
Slab Drain	each	X

Cost of any required excavation for bridge will be considered completely covered by the contract unit price for other items.

Estimated Quantities for Slab on Steel		
Item		Total
Class B-2 Concrete	cu. yard	x
Reinforcing Steel (Epoxy Coated)	pound	x

The table of Estimated Quantities for Slab on Steel represents the quantities used by the State in preparing the cost estimate for concrete slabs. The area of the concrete slab will be measured to the nearest square yard longitudinally from end of slab to end of slab and transversely from out to out of bridge slab (or with the horizontal dimensions as shown on the plan of slab). Payment for stay-in-place corrugated steel forms, conventional forms, all concrete and epoxy coated reinforcing steel will be considered completely covered by the estimated quantities but the variations cannot be used for an adjustment in the contract unit price.

Method of forming the slab shall be in accordance with Sec 703. All hardware for forming the slab to be left in place as a permanent part of the structure shall be coated in accordance with ASTM A123 or ASTM B633 with a thickness Class SC 4 and a finish Type 1, II or III.

Slab shall be cast-in-place with conventional forming or stay-in-place corrugated steel forms. Precast prestressed panels will not be permitted.

For Optional Stay-In-Place Form Details, see Sheet No. 2.

**REPAIRS TO BRIDGE:
ROUTE * OVER ***

ROUTE * FROM * TO *
ABOUT * MILES * OF *
BEGINNING STATION ± (MATCH EXISTING)

DATE PREPARED 3/7/2024	
ROUTE	STATE MO
DISTRICT	SHEET NO. BR REDECK01
COUNTY	
JOB NO.	
CONTRACT ID.	
PROJECT NO.	
BRIDGE NO.	

DATE	DESCRIPTION

MISSOURI HIGHWAYS AND TRANSPORTATION COMMISSION

105 WEST CAPITOL
JEFFERSON CITY, MO 65102
1-888-ASK-MODOT (1-888-275-6636)

Standard Drawing Guidance (do not show on plans):
(Turn off Level Bridge-Constructions to hide)

- ① Remove if not required; may be incorporated into half section slab details.
- ② Use this note only when specified in Bridge Memo or Design Layout.
- ③ For skewed bridges, add these items to section details to call out varied transverse bars at end bent.
- ④ Note is required only when shop drawings will be required (For example, expansion device replacement, diaphragm replacement, etc.)

④ Bar spacing shown is for Type D barrier. Below spacing may be used for Type H barrier.

Roadway	22 feet	22 feet	24 feet	24 feet	26 feet	26 feet
Beam Spa.	4 @ 6'-8"	4 @ 6'-0"	4 @ 6'-10"	4 @ 6'-8"	4 @ 7'-8"	4 @ 7'-4"
Bar Spa.	7"	7½"	8"	7½"	8"	8"
Roadway	28 feet	30 feet	32 feet	34 feet	38 feet	
Beam Spa.	4 @ 8'-0"	4 @ 8'-8"	4 @ 9'-4"	5 @ 7'-6"	5 @ 8'-6"	
Bar Spa.	8"	8"	8"	8"	6"	

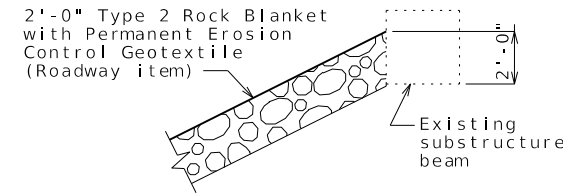

ROCK BLANKET ON SPILL SLOPES

Use when Rock Blanket is specified on BR Memo.

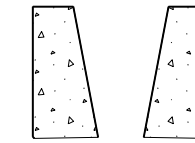

Type H Barrier

Structural Steel Protective Coating:

A4a1.21

Protective Coating: System G in accordance with Sec 1081 except thinners are not permitted.

Surface Preparation: Surface preparation of the existing steel shall be in accordance with Sec 1081 for Overcoating of Structural Steel. The cost of surface preparation will be considered completely covered by the contract lump sum unit price per sq. foot for Surface Preparation for Overcoating Structural Steel (System G). A4a1.22

Field Coat(s): The color of the field overcoat shall be Gray (Federal Standard #26373) Brown (Federal Standard #30045) Black (Federal Standard #17038) Dark Blue (Federal Standard #25052) Bright Blue (Federal Standard #25095) and shall be applied in accordance with Sec 1081.10.3.4. The cost of the intermediate field coat will be considered completely covered by the contract lump sum unit price per sq. foot for Intermediate Field Coat (System G). The cost of the finish field coat will be considered completely covered by the contract lump sum unit price per sq. foot for Finish Field Coat (System G). A4a1.23

(Existing Bearings at End Bents and Int. Bents)

Structural Steel Protective Coating:

Protective Coating: System G in accordance with Sec 1081. All existing bearings shall be recoated with System G.

A4a1.9 (Modified)

Surface Preparation: Surface preparation of the existing steel shall be in accordance with Sec 1081 for Recoating of Structural Steel (System G, H or I) with organic inorganic zinc primer. The cost of surface preparation will be considered completely covered by the contract unit price for Recoating Existing Bearings.

A4a1.10 (Modified)

Prime Coat: The cost of the prime coat will be considered completely covered by the contract unit price for Recoating Existing Bearings. Tint of the prime coat for System G shall be similar to the color of the field coat to be used.

A4a1.11 (Modified)

Field Coat: The color of the finish field coat shall be Gray (Federal Standard #26373). The cost of the intermediate field coat will be considered completely covered by the contract unit price for Recoating Existing Bearings. The cost of the finish field coat will be considered completely covered by the contract unit price for Recoating Existing Bearings.

A4a1.12 (Modified)

Sec 1081.10.4.6 shall be modified such that the word "RECOATED" is replaced by the word "RECOATED - SYSTEM G - BEARINGS ONLY".

(Structures with Exposed Piling)

Structural Steel Protective Coating:

A4a3.2

All exposed surfaces of the existing structural steel piles shall be coated with one 6-mil thickness of aluminum gray epoxy-mastic primer applied over an SSPC-SP3 surface preparation in accordance with Sec 1081. The bituminous coating shall be applied one foot above and one foot below the existing ground line and in accordance with Sec 702. These protective coatings will not be required below the normal low water line. The cost of surface preparation will be considered completely covered by the contract lump sum price for Surface Preparation for Applying Epoxy-Mastic Primer. The cost of the aluminum gray epoxy-mastic primer and bituminous coating will be considered completely covered by the contract lump sum price for Aluminum Gray Epoxy-Mastic Primer.

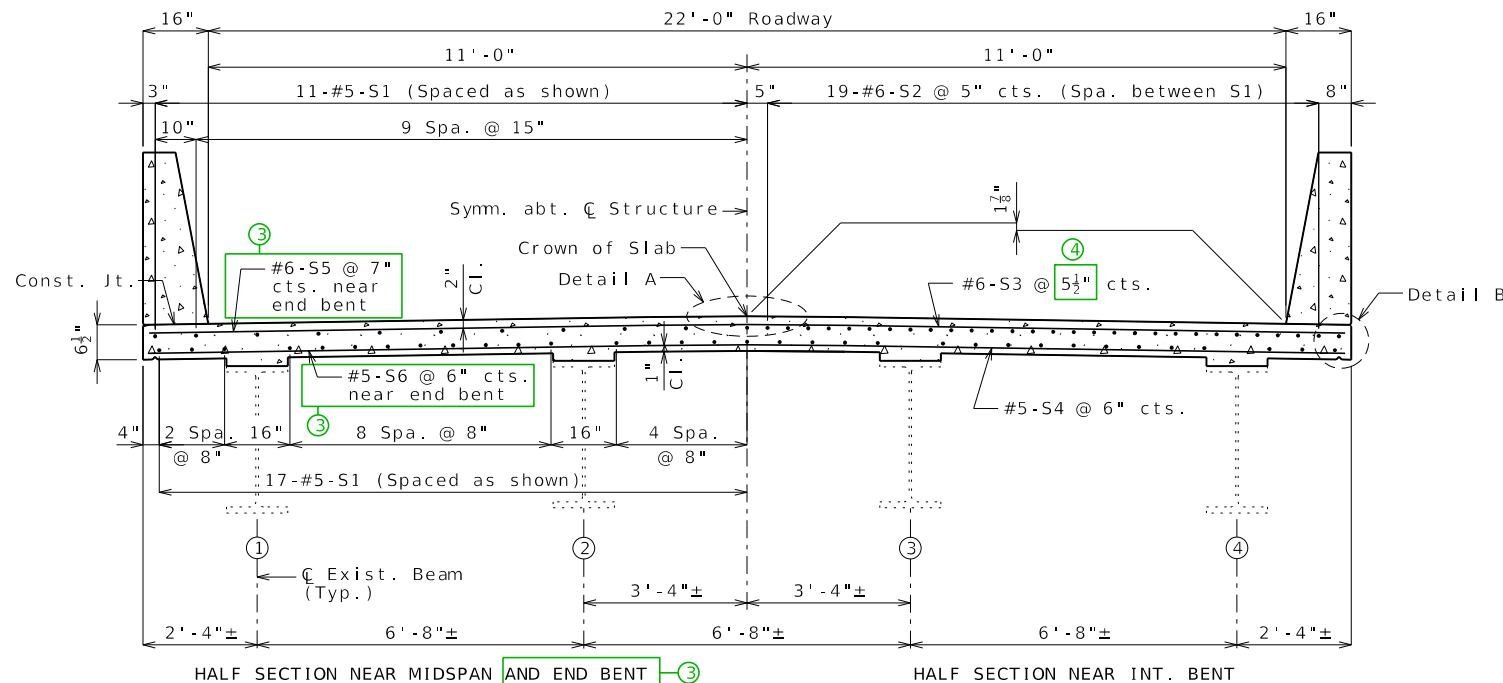

TYPICAL SECTION THRU SLAB
22' RDWY-4 BEAMS @ 6'-8"
*** SKEWED BRIDGES ***

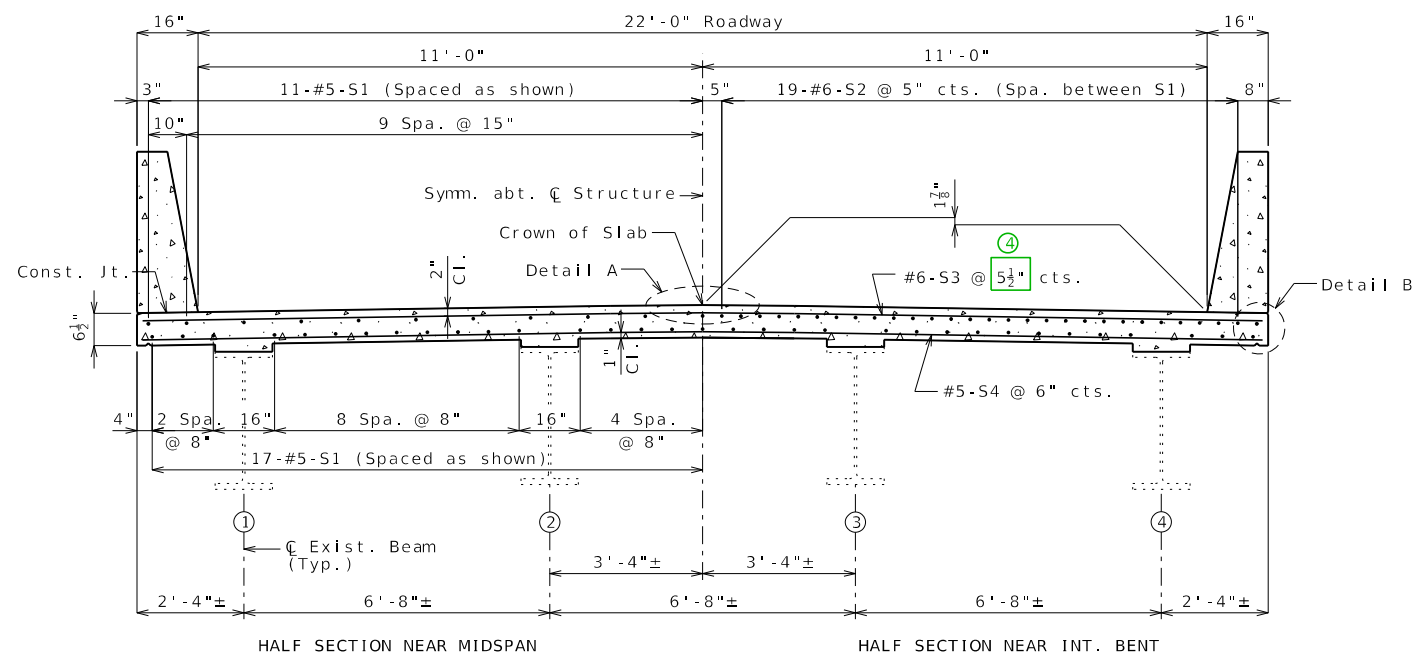

TYPICAL SECTION THRU SLAB

22' RDWY-4 BEAMS @ 6'-8"

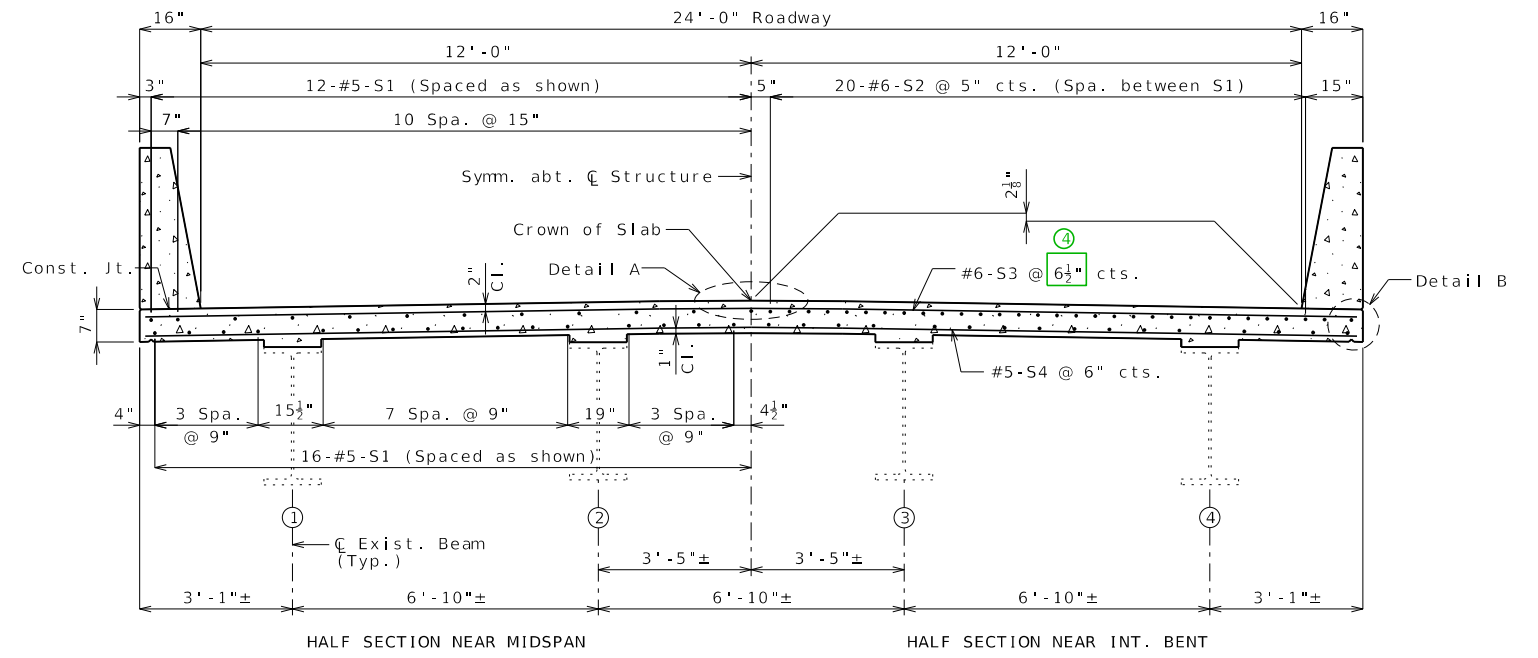

TYPICAL SECTION THRU SLAB

24' RDWY-4 BEAMS @ 6'-10"

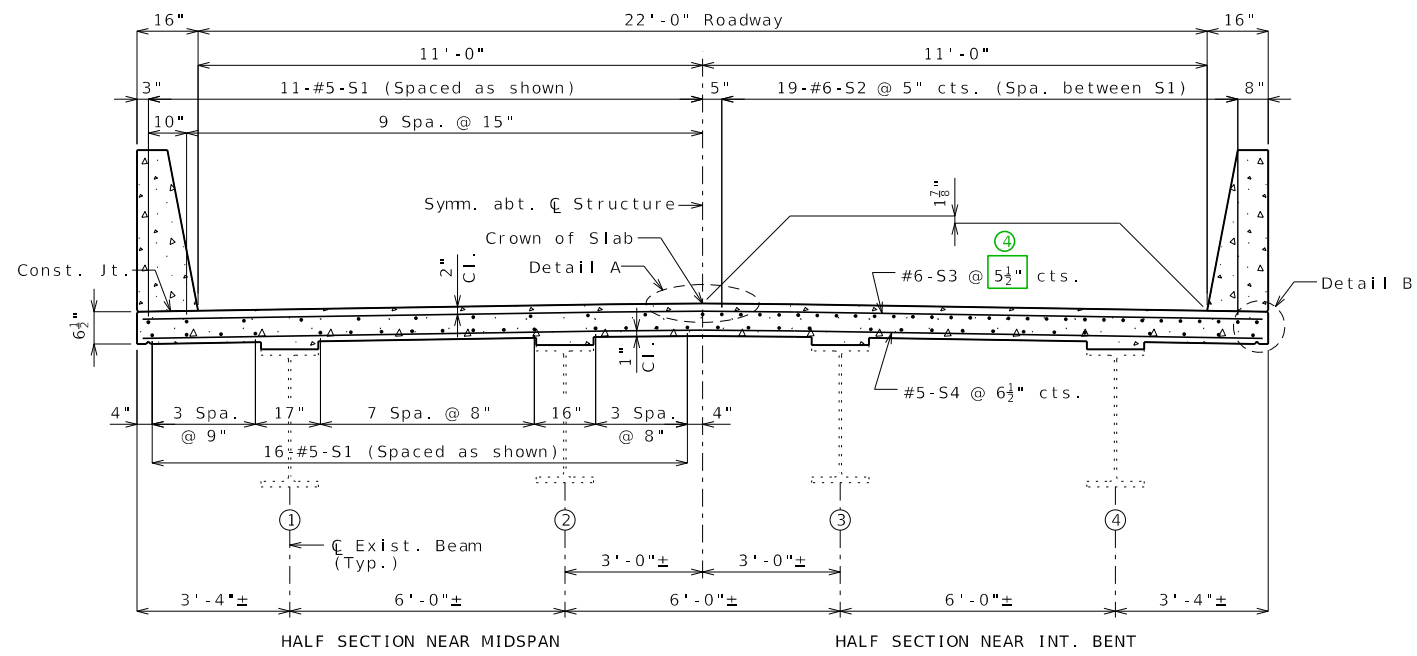

TYPICAL SECTION THRU SLAB

22' RDWY-4 BEAMS @ 6'-0"

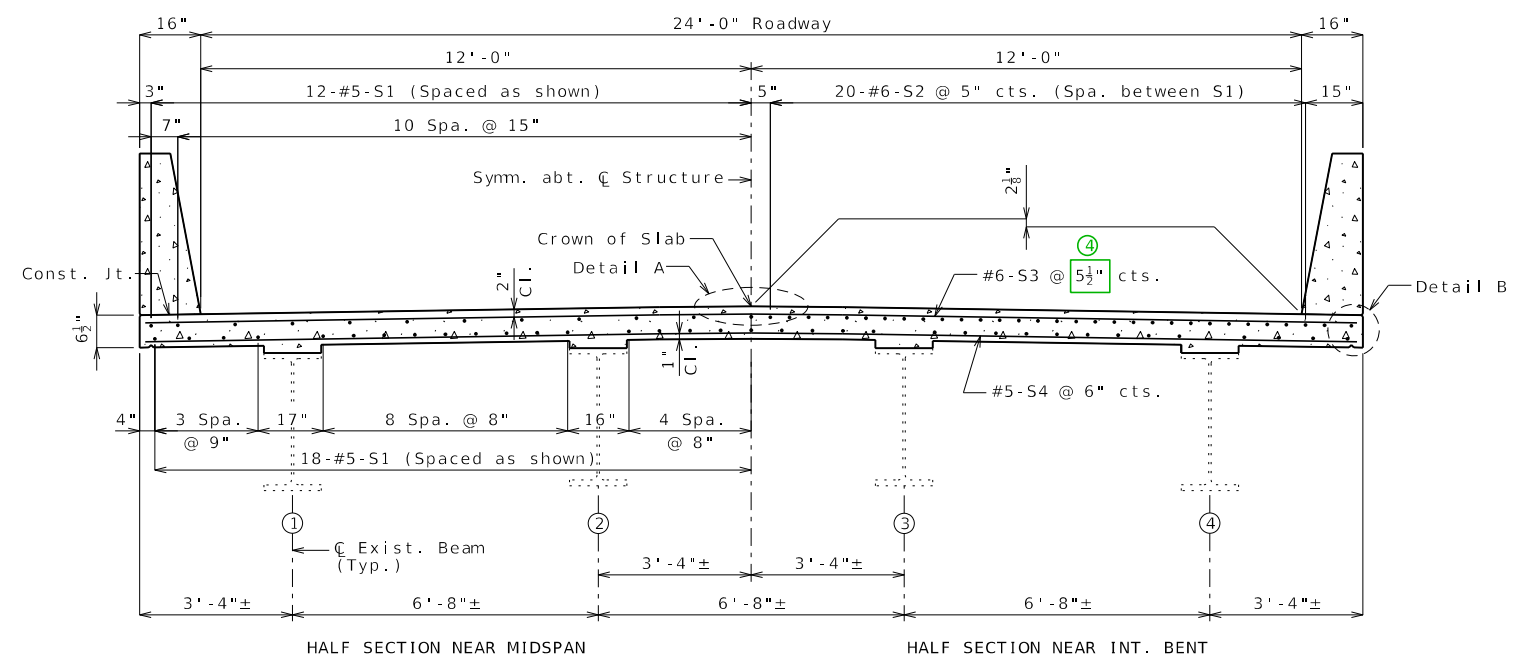

TYPICAL SECTION THRU SLAB

24' RDWY-4 BEAMS @ 6'-8"

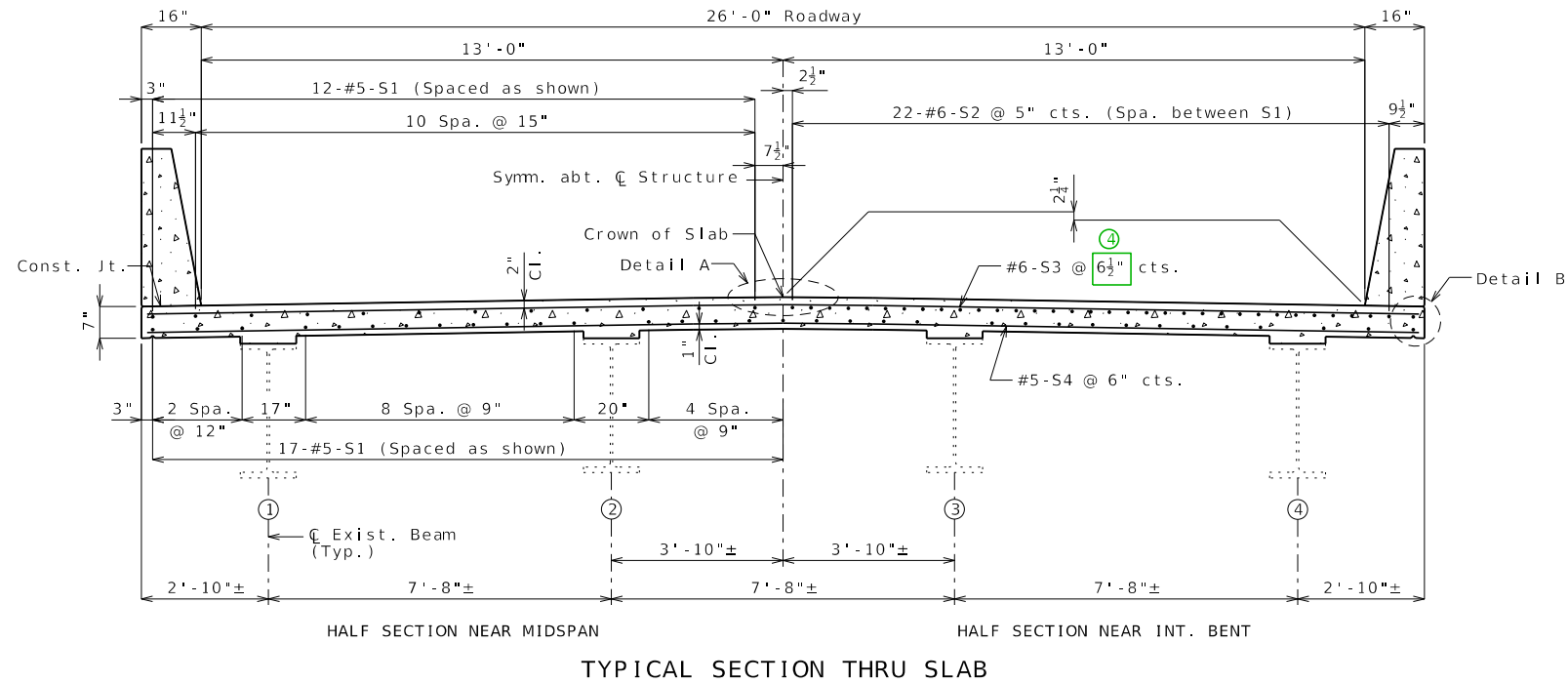

26' RDWY-4 BEAMS @ 7'-8"

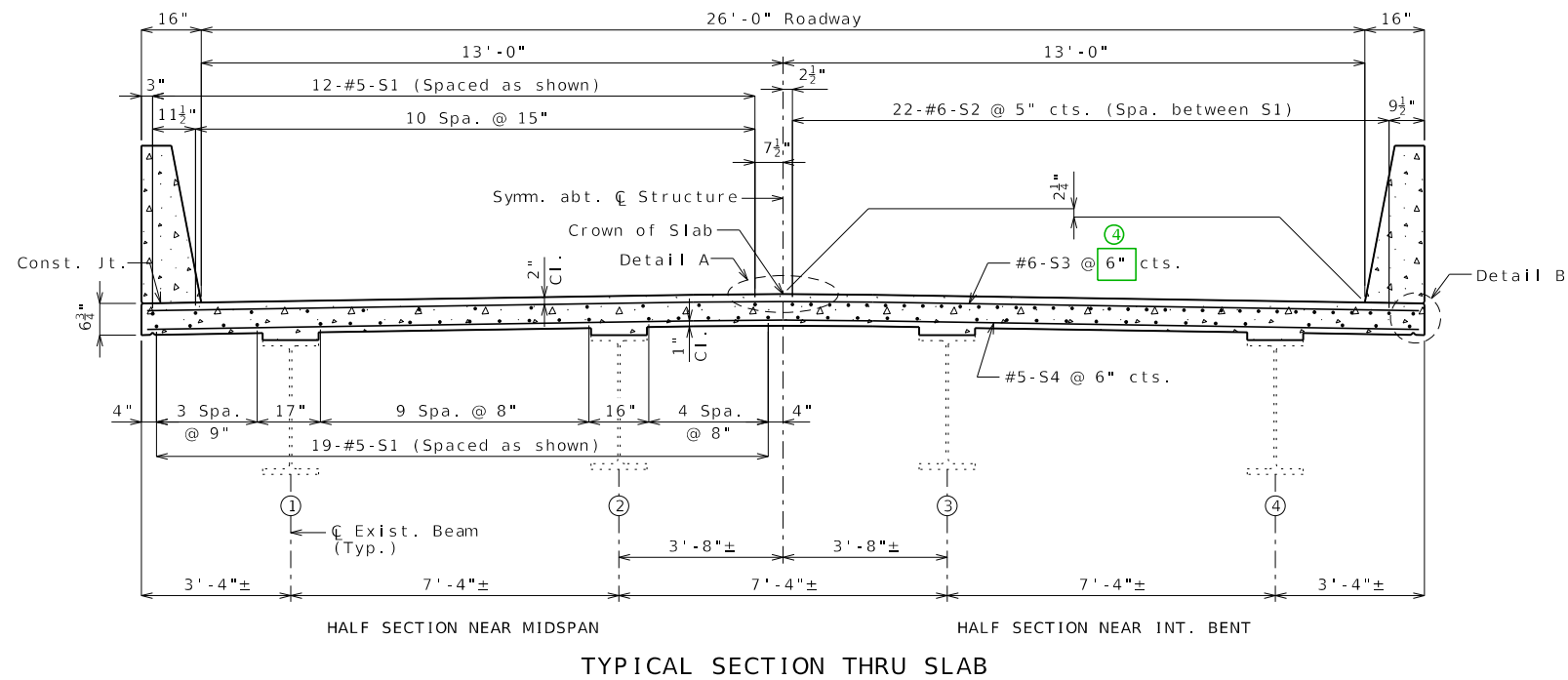

26' RDWY-4 BEAMS @ 7'-4"

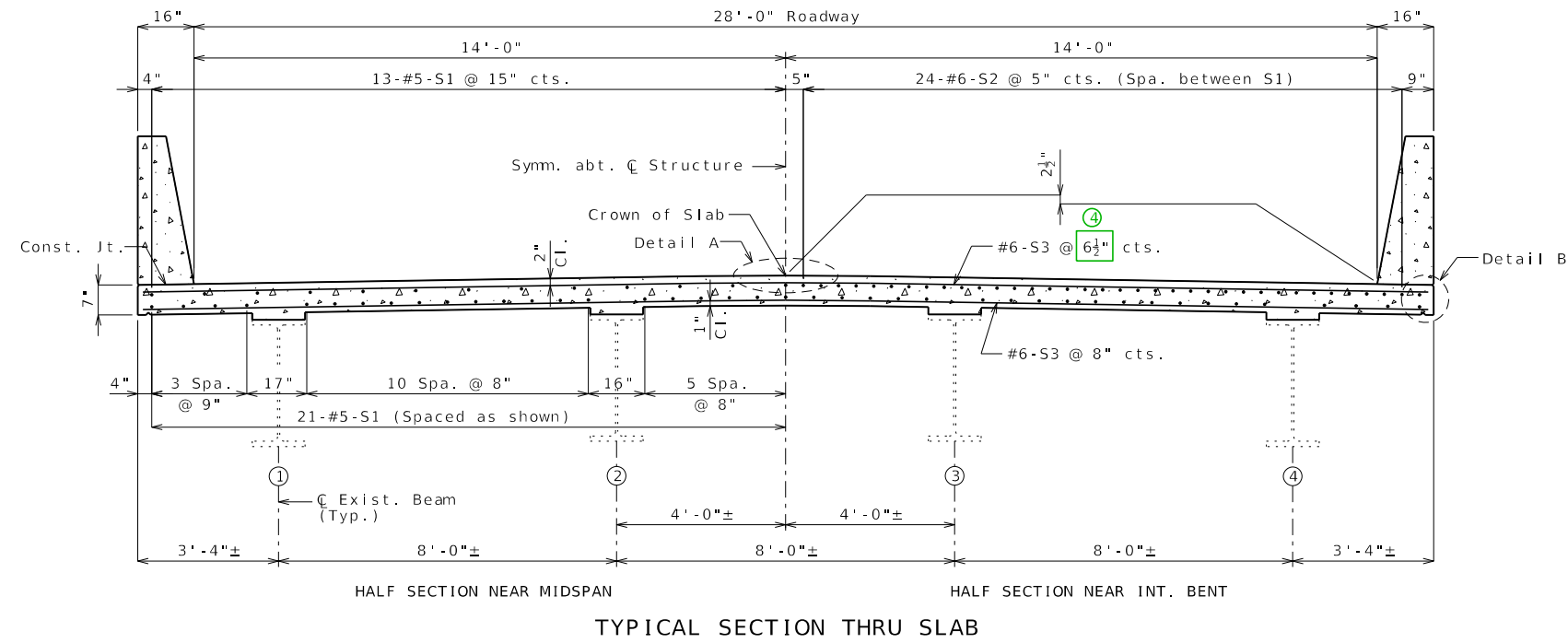

28' RDWY-4 BEAMS @ 8'-0"

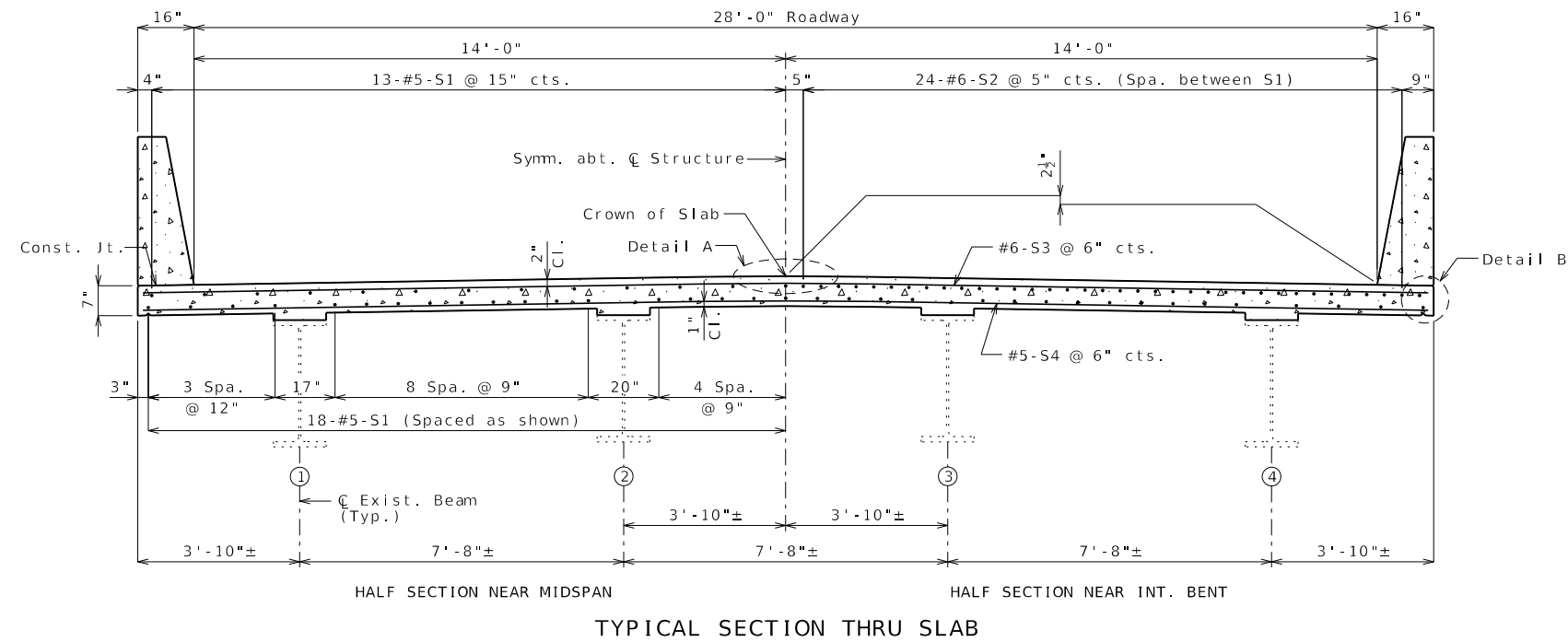

28' RDWY-4 BEAMS @ 7'-8"

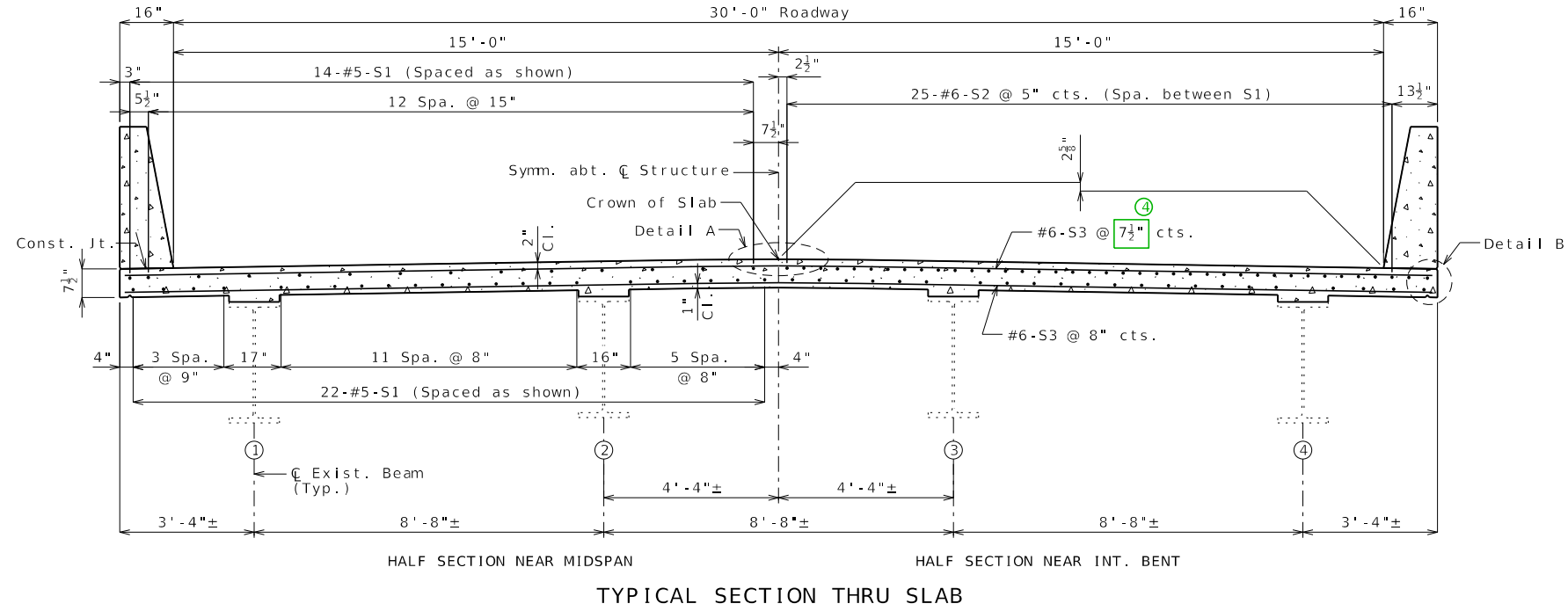

30' RDWY-4 BEAMS @ 8'-8"

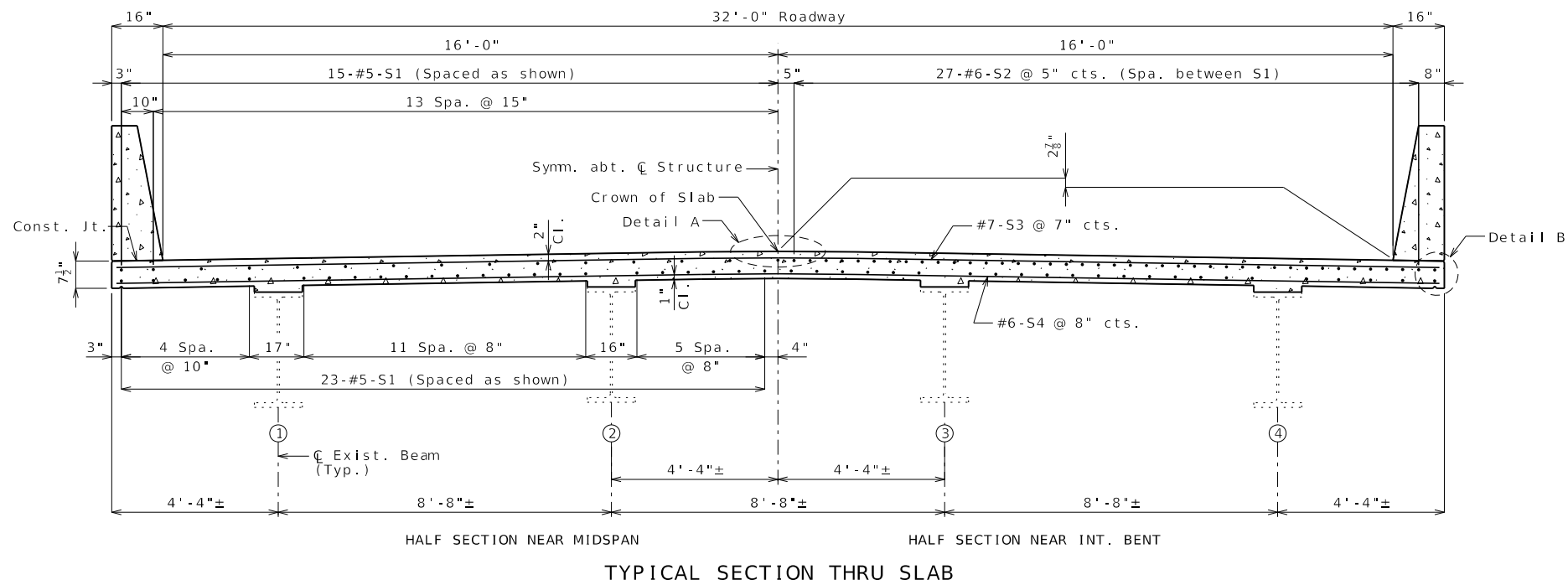

32' RDWY-4 BEAMS @ 8'-8"

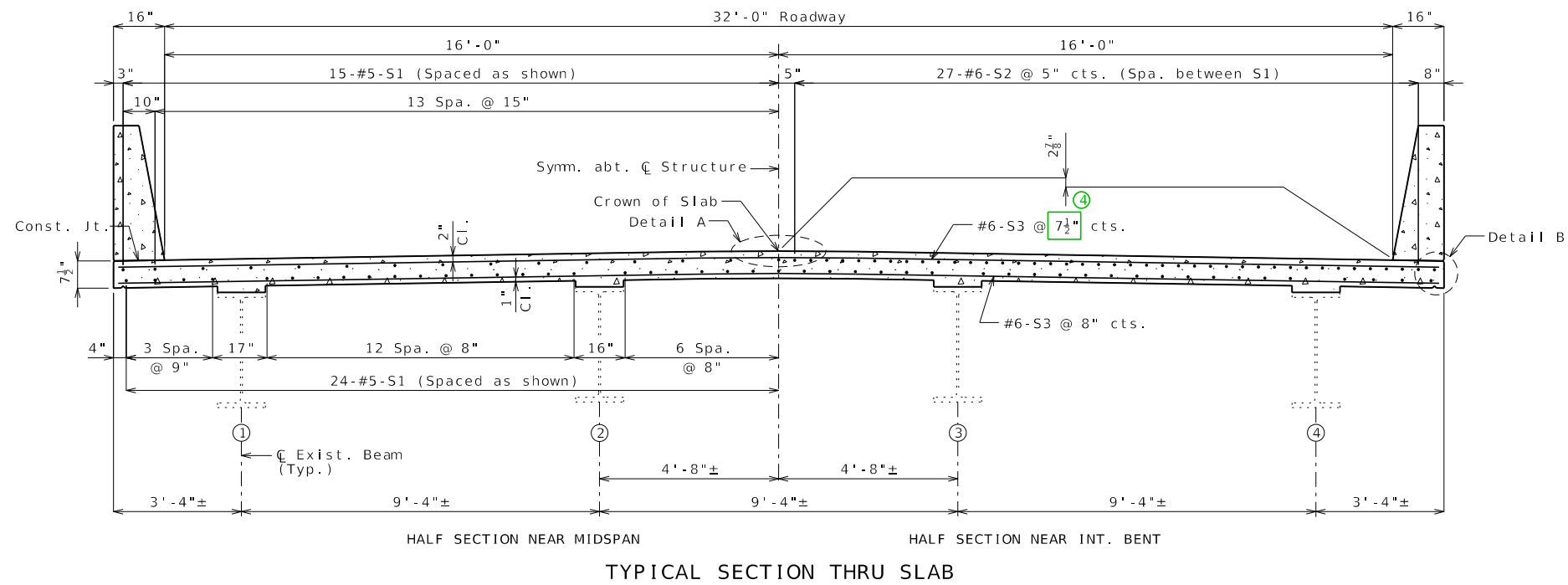

32' RDWY-4 BEAMS @ 9'-4"

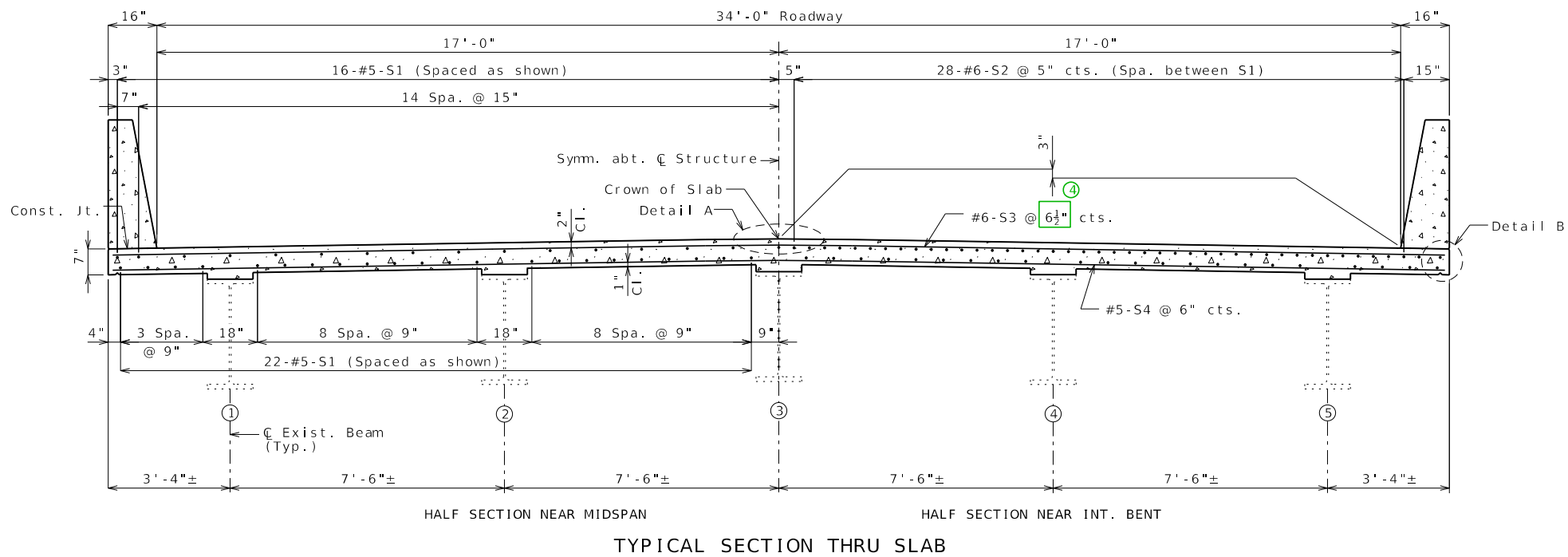

34' RDWY-5 BEAMS @ 7'-6"

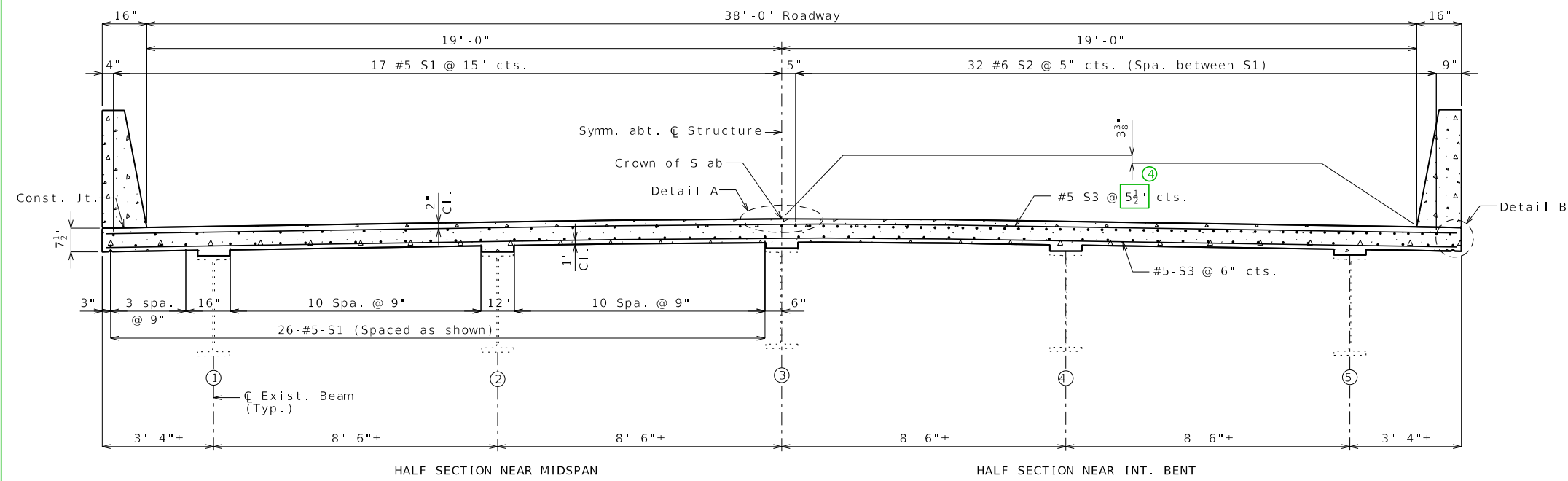

TYPICAL SECTION THRU SLAB

38' RDWY-5 BEAMS @ 8'-6"